

ROCKWOOL® is the registered trademark of ROCKWOOL Group.



# ROCKWOOL Curtain Wall Insulation



## ROCKWOOL CHINA

### Factory:

**Qingyuan**  
No.1, Chuangkang Rd, Guangfo Industrial Park,  
Fogang County, Qingyuan, Guangdong, P.R.C. (511675)  
Tel: 0763-4628899

**Yangzhou**  
No.5, 4th Keyan Rd, Yizheng Econ & Tech  
Development Zone, Jiangsu Province (211400)  
Tel: 0514-89189988

**Beijing**  
Tel: (+86) 10 6590 6077

**Shanghai**  
Tel: (+86) 21 6211 6725

**Guangzhou**  
Tel: (+86) 20 3839 3636  
Fax: (+86) 20 3839 3637

**Hong Kong**  
Tel: (+852) 2754 0877

**Taiwan**  
Tel: (+886) 4 2253 6866

**Philippine**  
Tel: (+63) 2 7710 650  
Fax: (+63) 2 7710 649

ROCKWOOL China Hotline: 400 665 0505

RW-CN/CW-BRO/06-2022/Z/EN



[www.rockwool.com.cn](http://www.rockwool.com.cn) ROCKWOOL Wechat

Improve Energy Efficiency  
Reduce Carbon Footprint  
Ensure Sustainable Development



## ROCKWOOL Group

We are the world leading stone wool manufacturer, with innovative products and systems, committed to protecting the environment and improving people's life.

ROCKWOOL Group is a global leader in thermal insulation, providing world-class firesafe and thermal insulation products and solutions for building structures. Our products help secure fire safety and reduce energy consumption of buildings, coupled with excellent performance in sound absorption, noise reduction and indoor comfort. ROCKWOOL provides green solutions for the horticulture industry, special engineered stone wool fiber for the manufacturing industry, as well as effective insulation solutions for refining and processing industries, marine and offshore industries and other areas. We also have acoustic and vibration reduction system for modern infrastructure construction.

ROCKWOOL Group has a major market share in Europe, but we have also actively expanded our market in Russia, North America, India and East Asia, with more production, sales and service activities operating locally. ROCKWOOL Group's global network helps promote our products and systems around the world.

Headquartered in Denmark, ROCKWOOL group is a listed company of NASDAQ OMX Nordic exchange Copenhagen. At present, it has 51 manufacturers around the world, nearly 12,000 employees and a sales network of more than 120 countries and regions around the world. At the level of corporate governance, ROCKWOOL has a perfect organizational structure and decision-making mechanism of listed companies, which are supervised and managed by the group's management, the board of directors and the

general meeting of shareholders respectively, and the audit committee and Remuneration Committee ensure the smooth development of the group's business strategy.

In China, ROCKWOOL provides a wide range of products for building insulation and other industrial areas that cater to different applications. We have more than 20 years of exploration and operation in China. ROCKWOOL stone wool is integrated with several excellent strengths: fire resilience, thermal properties, acoustic capabilities, durability and sustainability etc. Our products can stand the test of time. They protect buildings and people in any environment while reducing the carbon footprint. ROCKWOOL protects the environment and makes our society develop with a more sustainable approach.

ROCKWOOL China has an annual stone wool production capacity of 100,000 tons in Qingyuan and Yangzhou, and subsidiaries located in Beijing, Guangzhou, Hong Kong, Taiwan, Philippines and other major cities at present.

**100** Times

Energy saved in the life cycle of building application is 100 times than energy consumption during the production.

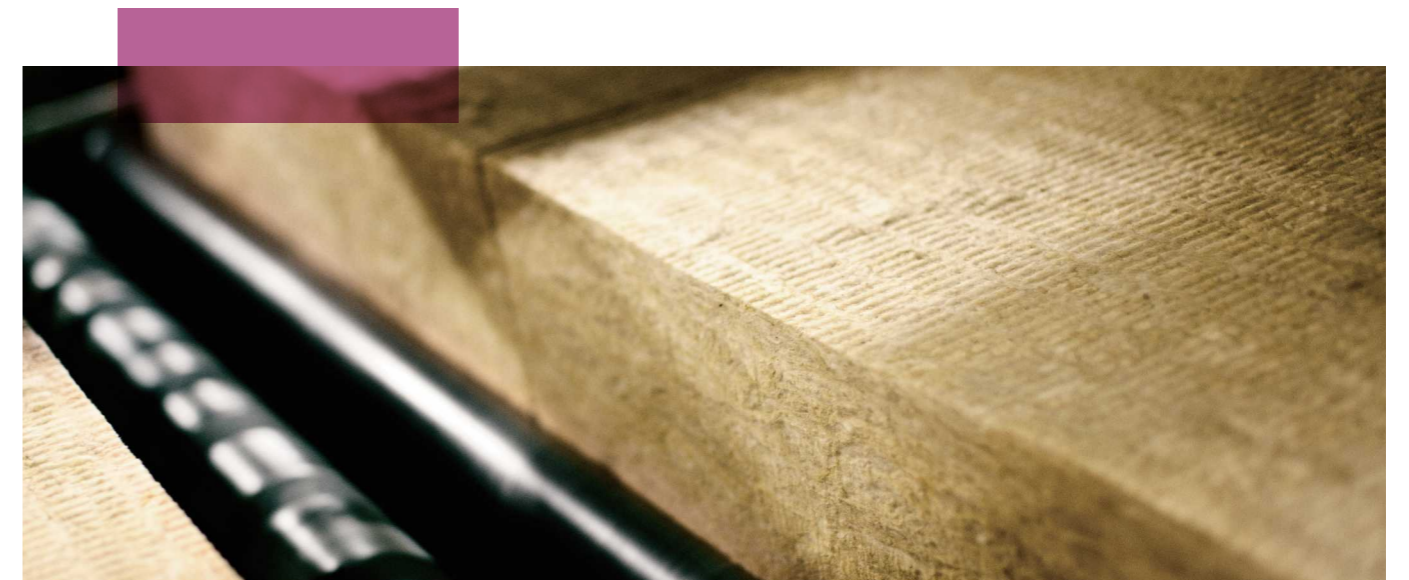

# ROCKWOOL Curtain Wall Insulation

Designed for curtain wall system, ROCKWOOL curtain wall insulation can be applied to the main structure, fireproof partition and fire blocking required for certain fire resistance requirements. The product series meet the European CE certification requirements.

ROCKWOOL curtain wall insulation products are made of stone wool by unique formula. The high thermal stability and remarkable resistance to thermal shrinkage help stabilize the structure of stone wool fiber under high temperature, effective in preventing or slowing the spread of fire.

ROCKWOOL curtain wall insulation is dark brown, easily recognized. Products are categorized by use: RS series for fire and smoke sealing at gaps and CUR series for backpan of curtain wall. The combination of RS and CUR series provides an all-in-one solution to fire insulation with a high level of fire resistance for curtain wall construction.



Product Series	Product Code	Product Name
RockSafe	RS60	RockSafe
	RS80	RockSafe Plus
	RS110	RockSafe Pro
CurtainRock	CUR110	CurtainRock 80 Plus
	CUR128	CurtainRock 80 Pro

## RS and CUR Applications in Curtain Wall System

Suitable to curtain wall systems made of glass, metal, stone boards and other materials

- ① CUR stone wool slabs are fixed to the frame of wall between windows or the backer board of curtain wall by fastenings;
- ② Aluminium alloy or metal frame is fully covered by CUR stone wool slabs as a way of fire protection;
- ③ RS stone wool slabs are fixed and compressed by Z-type steel studs;
- ④ The stiffener serves as a support along the floor with a higher strength;
- ⑤ The gap and opening of RS stone wool slabs are completely closed by smoke-gas proof sealant.

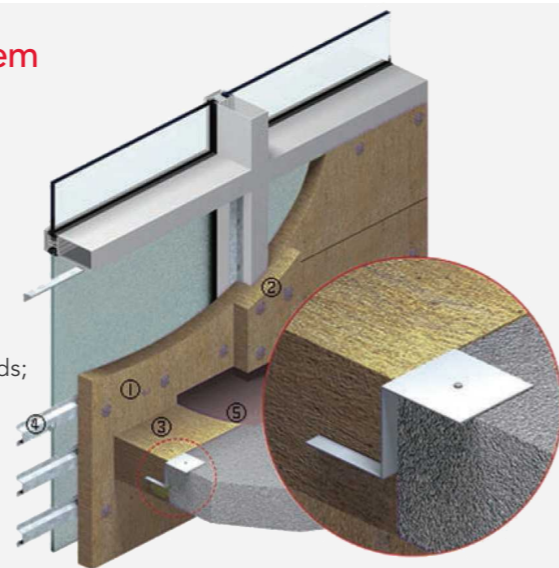

## ROCKWOOL RockSafe series

RS series are tailored to the fire blocking of curtain wall, mainly between layers, units and walls. RS series can effectively prevent fire and smoke from developing to other building units or floors, controlling the spread of fire.

### Specifications

	RS Series		
	RS60	RS80	RS110
Nominal density	60kg/m <sup>3</sup>	80kg/m <sup>3</sup>	110kg/m <sup>3</sup>
Thickness	100-200mm		
Size	1200mm x 600mm		

Note: Please contact your local sales representatives for sizes and thickness not stated in the data sheet.

### Applications

Fire blocking for curtain wall: cavities between curtain wall and floorboard, between curtain wall and main structure; firewall openings, floor expansion joints and other necessary openings or gaps of fireproof partition with a certain fire resistance requirements.

### Products

RS60 and RS80 series are for areas required for a higher compression ratio, such as vertical separation between curtain wall units and areas between vertical profile and walls that are subject to deformation; RS110 series are for areas with a lower compression ratio, such as the joints of curtain wall and connections.

**Strong thermal stability and remarkable resistance to thermal shrinkage under high temperature**

## ROCKWOOL CurtainRock series

CUR series are used for the fire blocking of wall between windows and between window and sill, serving as fireproof separation between layers and units of curtain wall. CUR series can prevent the fire from spreading to higher floors or adjacent buildings through windows or layers. The stone wool of CUR products has good performance in thermal insulation, sound isolation and noise reduction.

### Specifications

	CUR Series	
	CUR110	CUR128
Nominal density	110kg/m <sup>3</sup>	128kg/m <sup>3</sup>
Thickness	50mm, 75mm, 100mm	
Size	1200mm x 600mm	

Note: Please contact your local sales representatives for sizes and thickness not stated in the data sheet.

### Applications

- Thermal and fire insulation of wall between windows and wall between window and sill;
- To protect load bearing beams that may be exposed to high temperature in case of fire.

### Products

CUR series include CUR110 and CUR128. They are manufactured into different densities and strengths, chosen upon the structure of curtain wall.

- CUR110: If the rear slab of wall between windows is of high strength due to the support of steel frame and silicate fire boards, or walls between window and sill are independent, CUR110 can be used as fillings to fit the need of fire resistance with a lower cost;
- CUR128: If stone wool slabs with aluminum foil are exposed outside or steel plates used have relatively low strength, wall between windows is likely to deform internally under a certain amount of pressure. Since the fire blocking between layers can exert certain pressure to the stone wool, CUR128 of higher strength is preferred in this structure.

# Excellent Fire Performance

## Remarkable fire safety for curtain walls

ROCKWOOL RS series use special formula to enhance fire performance, with a melting point higher than 1200°C, providing outstanding fire safety for curtain walls.

- RS series products have all passed the integrity and insulation tests for fire rating, fire resistance lasting 1-2 hours (Standard: BS476Part20 and GB/T9978). As for installation, products shall be tightened by width (Recommendation: compressed by 15%) and then filled in openings of the concrete floor;
- CUR series also have superior performance in fire protection and resistance when applied to non-transparent thermal insulation layers, protecting building components by sustained effectiveness in fire over long periods of time. The level of overall fire safety can be significantly elevated by the combination with RS series.

## Fire protection and key design points for curtain wall

- **Non-combustible:**  
ROCKWOOL curtain wall insulation is an A1 non-combustible material.
- **Thermal insulation:**  
ROCKWOOL curtain wall insulation can sustain a high temperature up to 1200°C while still maintaining a good performance in thermal insulation.
- **Structural integrity:**  
ROCKWOOL curtain wall insulation has good resistance to shrinkage under high temperature. The flexible stone wool fibers can cushion against deformation under high temperature, effectively preventing deformed material from falling off or even leading to collapse of the whole structure.
- **Toxic smoke stopping:**  
ROCKWOOL curtain wall insulation is effective in stopping toxic smoke or gas spreading among floors or adjacent building units. ROCKWOOL stone wool is an inorganic material, no toxic or harmful smoke gas produced under high temperature.

### Fire performance

	Standard	RS Series			CUR Series	
		RS60	RS80	RS110	CUR110	CUR128
Fire resistance limit	GB/T 9978.1-2008 or BS476 Part20	1-2h	1-2h	1-2h	N/A	N/A
Combustion performance	GB8624-2012	A1 Class				
Surface combustion	ASTM E84	Fire spread index: 0 Smoke spread index: 0				
Thermal contraction rate	ASTM C356	<2% (Temperature 650°C)				

### Fire reactions of different materials

1. Organic material starts cracking and burning after 2 minutes at a temperature lower than 300 °C;
2. Ordinary mineral wool starts melting (glass wool) after 6 minutes at a temperature around 600 °C;
3. Aluminum material starts melting after 9 minutes at a temperature around 700 °C;
4. Curtain wall glass starts melting after 25 minutes at a temperature around 800 °C;
5. Curtain wall stone wool insulation still maintains the integrity and continues thermal insulation after 4 hours at a temperature exceeding 1000 °C.

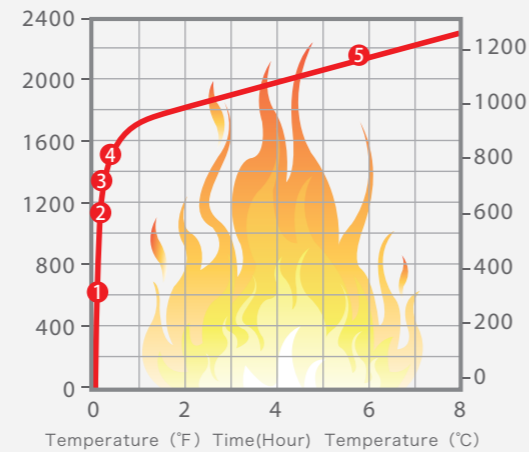

# Outstanding Comprehensive Performance



Enhanced fire performance, melting point higher than 1200°C

### Sustained insulation

- Lower thermal conductivity, 0.034W / m · K (Average temperature: 25°C);
- Dimensional stability, securing the stability of insulation performance over long periods;
- No CFCs, HCFCs or other substances that may cause a decreased R value over time;
- Insulation optimization and protection of the entire structure.

### Environmental sustainability

- No CFC, HCFC or any other substances that are harmful to the environment;
- Zero ozone depleting potential (ODP) and global warming potential (GWP);
- No toxic or hazardous substances under fire or heat;
- Bonus for LEED rating by using ROCKWOOL curtain wall insulation.

### Unique waterproof and air permeability performance

- Dry construction; hydrophobic, no moisture absorption;
- No capillarity, moisture penetration prevented;
- Inorganic materials, no fungi/mold/bacteria;
- Good air permeability, enhanced system durability.

### Good acoustic performance

- Open-end fiber structure, good sound absorption;
- Excellent noise reduction and vibration damping, isolating external noise.

Note: Please contact your local sales representatives for more information about solutions to sound absorption and insulation.

### Thermal performance

	Standard	CUR Series	
		CUR110	CUR128
Thermal conductivity	GB/T 10295 OR ASTM C518	0.034W/(m·K) (25°C)	

### Moisture resistance

	Standard	RS Series			CUR Series	
		RS60	RS80	RS110	CUR110	CUR128
water repellency	GB/T 10299	≥99%				
Moisture absorption rate by weight	GB/T 5480	≤0.5% (50°C, 95%RH, 96 Hour)				

### Durable safety

	Standard	RS Series			CUR Series	
		RS60	RS80	RS110	CUR110	CUR128
Smell	ASTM C665-06	No obvious sign of smell				
Antibacterial ability	ASTM 1338	No bed for the growth of fungi or bacteria				
Formaldehyde emission	GB/T 19686	≤1.4 mg/ (kg· h).				

# Construction and Installation Guide

## Packaging and storage

- RS and CUR stone wool slabs are wrapped by polyethylene shrink film. During the transport and storage, products should be moisture-rain proof, no damage on the packaging (Recommendation: using waterproof plastic bag or wrapper);
- Products should be stored in a dry environment with good ventilation, rather than an open environment; products shall not touch the ground, instead they should be stacked on the shelf or the platform above the ground; products should avoid bearing too much pressure, and the height of pile should not exceed 2.5 meters unless support racks are applied;
- If it is necessary to pile products outdoors during the construction, this approach can only be considered as a way of temporary storage. The floor must be dry and flat while products shall be covered with waterproof material to prevent from rain or water on the ground;
- As for handling, products should not be pulled by ropes or hooks, damages to corners and stamping on them avoided.



## Cutting

Insulation slabs can be cut with a sharp knife, saw or other tools if necessary for the construction, but it may incur errors in size. For the accuracy of size during the construction, it is recommended to use special mechanical cutting equipment.

## Remind of CurtainRock installation

- CUR slabs are to fill in the wall between windows. The joints of slabs and of slabs and curtain wall frame must be tightly connected. Stone wool slabs shall be installed on the internal frame of wall between windows or backer boards of curtain wall by fastenings;
- The aluminum or metal frame for the middle layer of curtain wall system should be fully covered by CUR stone wool slabs to avoid the burning of fire;
- The aluminum foil in curtain wall slabs serves as vapor barrier. The joints of stone wool slabs as well as slabs and aluminum alloy frame should be sealed by aluminum foil tape;
- If CUR slabs have direct contact with RS slabs, then it is necessary for wall between windows to be supported by horizontal stiffeners or backer boards. The purpose is to protect the wall between windows and its fillings, avoiding deformation incurred by stone wool slabs that are squeezed and compressed;
- The thickness of CUR slabs should not be less than 50mm, and slabs and outside slabs of wall between windows (made of glass, metal, stone, etc.) should leave a cavity wider than 25mm in between.

## RockSafe Compressing Guidelines

RS insulation slabs can be installed only after being compressed. This is to guarantee the effectiveness of fire blocking in case of deformations or displacements during the use. In the curtain wall system, deformation of the place near studs is smaller; however, the middle area of curtain wall unit may be subject to large deformation. For example, the deformation in the middle of vertical profile may be more than 20mm. Principles of compressing:

- For the gap wider than 50mm, the design should consider the deformation of curtain wall under the positive and negative air pressure. It is to ensure the effectiveness of sealing with the largest deformation. The compression rate is recommended to be higher than 15%;
- For the vertical fire blocking such as the place between vertical profile and the structure, the deformation of the structure must be taken into account (e.g. the allowed deformation of vertical profile or curtain wall slabs). It is suggested that the compression takes the higher value between the two: thickness  $\times 1.05 +$  structural deformation or 15%;
- For 30-50mm wide gap, the compression could be 10mm;
- For the gap less than 30mm wide, it shall be sealed by fireproof sealant after being fully filled in.

Note: Please contact your local sales representatives for more information about compressing guidelines

## RockSafe installation

1. Cut RS slabs into strips by width required for compression. [Figure 1]
2. Insert one side of Z-type stud into the middle of stone wool insulation. The length inserted can be 50~75% of the gap. [Figure 1]

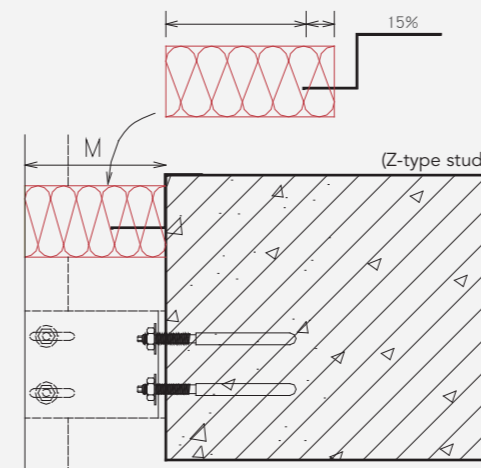

[Figure 1]

3. Coordinate the arrangement of RS slabs based on the spacing of curtain wall frame. For vertical aluminum alloy frame with a spacing of 1500mm, two different types of stone wool insulation can be used in combination (1200mm and 300mm). [Figure 2]
4. For 1200mm RS slabs, Z-type studs should be set 300mm inwards the slab, with a recommended spacing of 600mm. For stone wool slabs shorter than 1200mm, two Z-type studs in even distribution are also needed. [Figure 2]

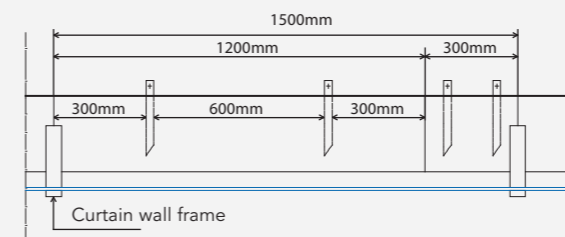

[Figure 2]

5. Install Z-type studs to the structure after compressed slabs and studs being filled in the gap. Please make sure no shifting or significant deformation incurred if pressing slabs by hand.
6. Close the gap between stone wool and the structure by smoke/gas-proof sealant (e.g. fireproof silicone sealant) (For the slab of which top covered by aluminum foil, joints shall be sealed by aluminum foil tape whereas the area around foil to be sealed by smoke sealant.) [Figure 3]

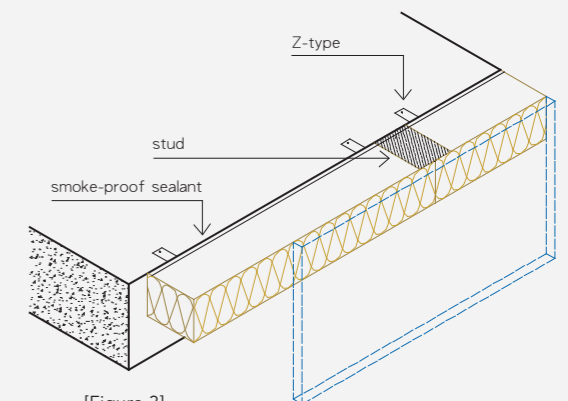

[Figure 3]

7. Insert slabs into the place between wall between windows and vertical profile, sealed by fireproof silicone sealant.
8. In some solutions, smoke/gas-proof flexible coating would be applied where the joints of slabs, slabs and the structure as well as slabs and curtain wall are all sealed. RS series combine the performance in stopping the spread of smoke with aesthetics. [Figure 4]

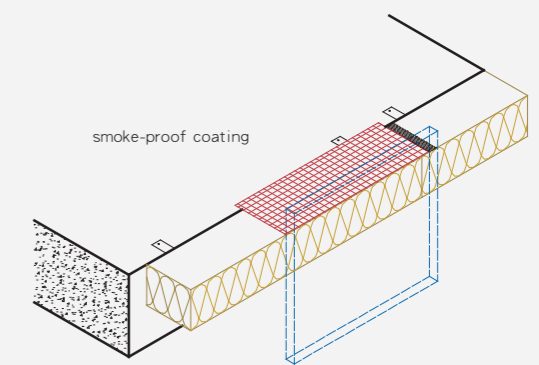

[Figure 4]

Note: joints must be tightly connected and compressed, no seam allowed; fastenings must be fire resistant, no plastic used

# ROCKWOOL Projects

Project	Location	Application	Product	Time of delivery
Inter Continental Beijing Beichen	Beijing	Passive fire protection	RS	2007
Beijing Olympic Sports Center Area	Beijing	Passive fire protection	RS	2007
BM Tower	Shanghai	Passive fire protection	RS	2008
Zendai Himalayas Center	Shanghai	Passive fire protection	RS	2009
Shenzhen AVIC Square	Shenzhen	Passive fire protection	RS	2009
TaiKoo Hui	Guangzhou	Passive fire protection	RS	2009
Shanghai Siemens Center	Shanghai	Passive fire protection	RS	2010
Leatop Plaza	Guangzhou	Passive fire protection	RS	2010
The Pinnacle	Guangzhou	Passive fire protection	RS	2011
KK100	Shenzhen	Passive fire protection	RS	2011
CCTV attached building reconstruction	Beijing	Passive fire protection	RS	2011
Shanghai Tower	Shanghai	Passive fire protection	RS	2011
Guangzhou Chow Tai Fook Center	Guangzhou	Passive fire protection	RS	2014
China Merchants Securities Tower	Shenzhen	Passive fire protection	RS	2014
Wang Jing SOHO	Beijing	Passive fire protection	RS	2014
St.Paul's Hospital	HongKong	Passive fire protection	CUR	2014
Shenzhen Tencent Building of Binhai	Shenzhen	Passive fire protection	RS	2015-2017
Shenzhen Pingan IFC	Shenzhen	Passive fire protection	RS	2015-2017
PWTC Expo	Guangzhou	Passive fire protection	RS	2015-2017
CTF Finance Centre	Guangzhou	Passive fire protection	RS	2015-2017
Changsha IFS	Changsha	Passive fire protection	RS	2015-2017
Qingdao Haitian hotel	Qingdao	Passive fire protection	RS	2018
Hangzhou SF Innovation Center	Hangzhou	Passive fire protection	RS	2018
The Chinese University of Hong Kong, Faculty of Medicine	HongKong	Passive fire protection	CUR	2018
MediaTek headquarter	Taipei	Passive fire protection	CUR	2019
Exop Green Valley	Shanghai	Passive fire protection	RS	2019
Zhenru sub center	Shanghai	Passive fire protection	RS	2019
Tai Wai station	HongKong	Passive fire protection	CUR	2019
Suzhou Metro	Suzhou	Passive fire protection	RS	2020
China Maristar	Zhangjiagag	Passive fire protection	RS	2020
Kwong Wah Hospital	Hong Kong	Passive fire protection	RS	2020
Fubon Financial Holding Headquarter	Taipei	Passive fire protection	CUR	2021
Kai Tak Industrial and commercial building	Hong Kong	Passive fire protection	CUR	2020-2021
SAMPO Group New Headquarter	Taoyuan	Passive fire protection	CUR	2021
Shinyi A25 Project	Taipei	Passive fire protection	CUR	2021
Kai Tak Residence NKIL6574	Hong Kong	Passive fire protection	CUR	2021-2022
Guanghua Hospital Reconstruction Project Phase I	Hong Kong	Passive fire protection	CUR	2020-2022



Unilever China(Shanghai)



Fortune Plaza(Beijing)

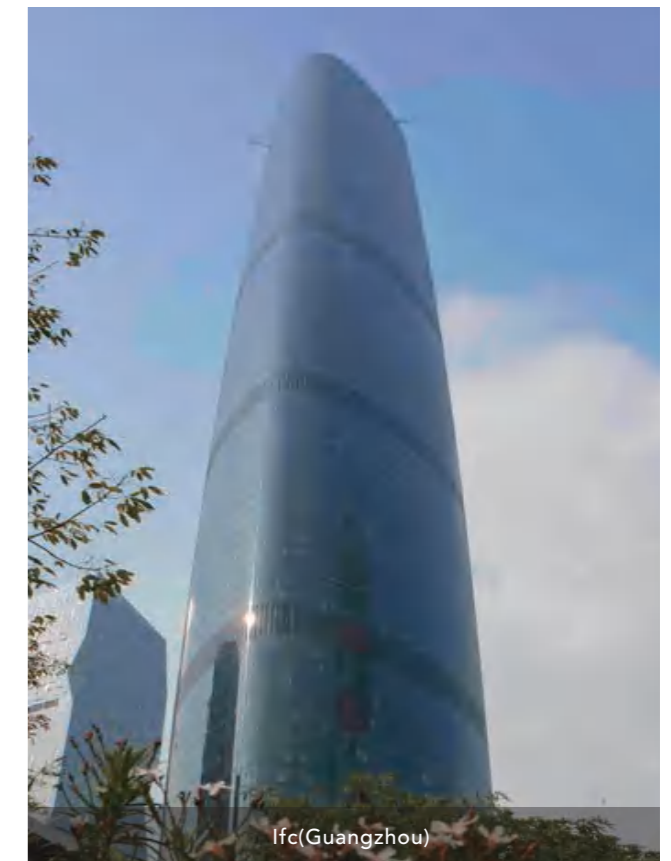

Ifc(Guangzhou)

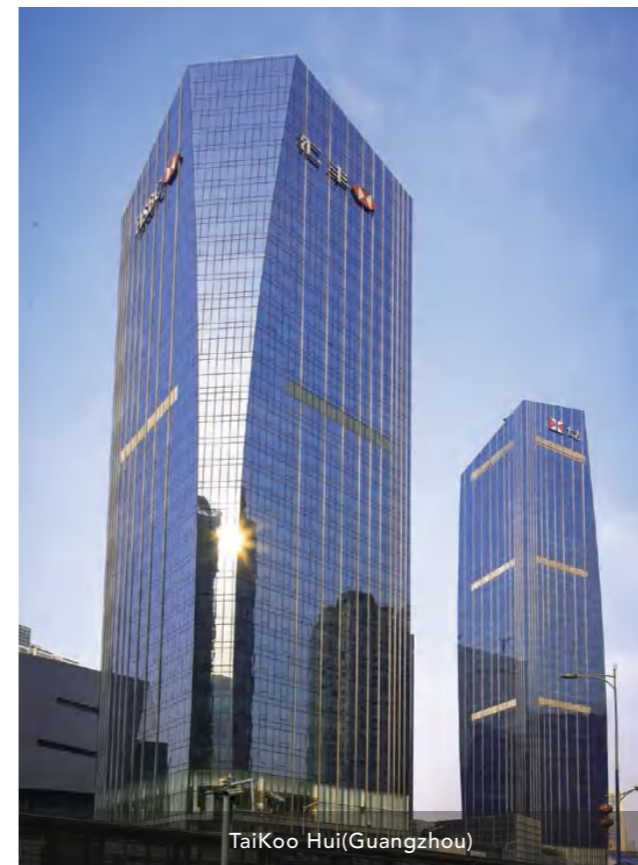

TaiKoo Hui(Guangzhou)

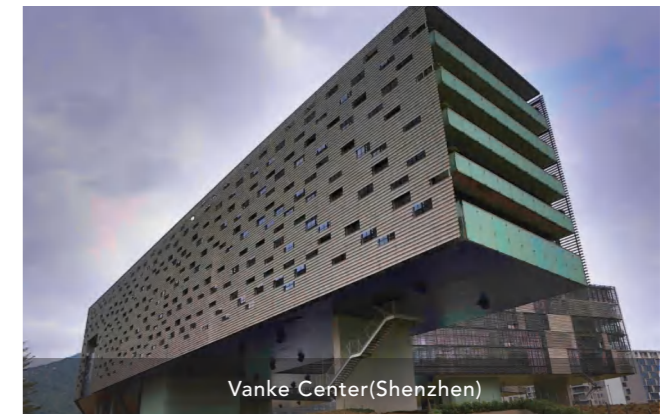

Vanke Center(Shenzhen)

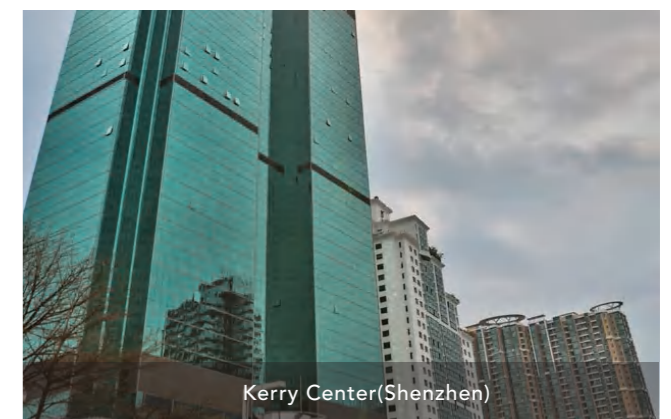

Kerry Center(Shenzhen)